

Double-Link Beam Load Cell



FEATURES

- Capacities: 50K to 125Klbs
- Stainless steel construction
- Certified to NTEP class IIIIL 10000 divisions
- Sealing: IP68
- Low profile, self-checking and self-centering
- Optimised design specially for weigh-bridge use
- Optional conduit adapter

OPTIONAL FEATURE

- FM approved for use in potentially explosive atmosphere

DESCRIPTION

The 9223 is a hermetically sealed, end loaded, centre supported double ended shear beam.

This product is suitable for a wide range of truck and rail scales. It is designed to use parallel link loading, considered by many weighing experts to be advantageous when compared to other loading techniques.

Fully welded stainless steel seals ensure high environmental integrity and provided that additional cable sealing is used, occasional submersion can occur without damage.

These products meet the stringent Weights and Measures requirements throughout USA.

APPLICATIONS

- Truck scales
- Railroad track scales
- "Legal for Trade" tank, bin and hopper weighing

OUTLINE DIMENSIONS in inches

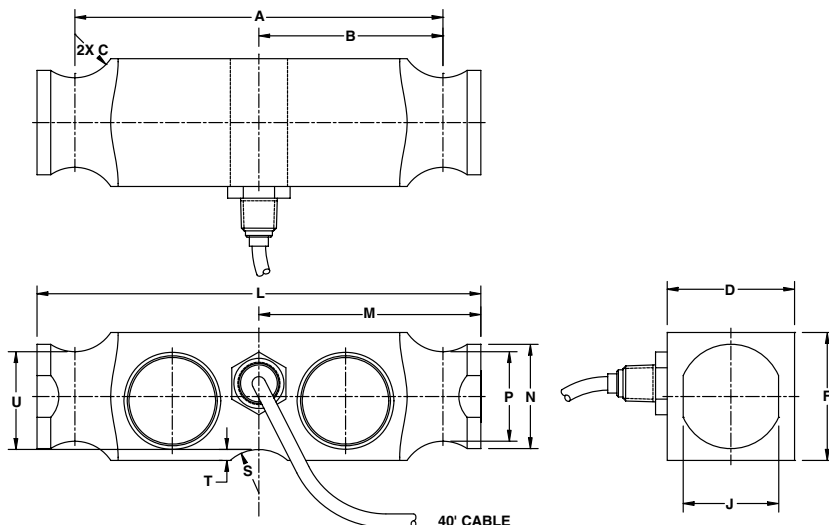

Cable specifications:

- Cable length: 40 feet
- Excitation + Red
- Excitation - Black
- Output + Green
- Output - White
- Shield Bare

Cable screen is not connected to load cell body. Performance may be affected if load cell cables are shortened.

Capacity (lb)	50K, 65K, 100K, 125K
A	8.50
B	4.25
C RAD	1.00
D	2.94
F	2.94
J	2.20
L	10.25
M	5.13
N	2.40
P	2.06
S RAD	1.00
T	0.25
U	2.25

SPECIFICATIONS

PARAMETER	VALUE		UNIT
	NTEP III L	Non-Approved	
Standard capacities (E_{max})	50, 65, 100, 125		Klbs
Accuracy class according to NTEP	NTEP III L	Non-Approved	
Maximum no. of verification intervals (n_{ic})	10000		
Rated output (=S)	3		mV/V
Rated output tolerance	0.003		±mV/V
Zero balance	1.0		±% FSO
Combined error	0.0200	0.0500	±% FSO
Non-repeatability	0.0100	0.0200	±% FSO
Creep error (20 - 30 minutes)	0.0300	0.0300	±% applied load
Temperature effect on minimum dead load output	0.0008	(0.0140)	±% FSO/°F (/5°C)
Temperature effect on sensitivity	0.0010	(0.0070)	±% applied load/°F (/5°C)
Compensated temperature range	-10 to +40 (+14 to 104)		°C (°F)
Operating temperature range	-53 to +93 (-65 to +200)		°C (°F)
Safe load limit	150		% E_{max}
Ultimate load	300		% E_{max}
Safe side load limit	100		% E_{max}
Excitation voltage recommended	10		V
Excitation voltage maximum	15		V
Input resistance	700±7		Ω
Output resistance	700±7		Ω
Insulation resistance	≥5000		MΩ
Environmental protection	IP68		
Element material	Stainless steel		ASTM

FSO-Full Scale Output

Disclaimer

All product specifications and data are subject to change without notice.

Vishay Precision Group, Inc., its affiliates, agents, and employees, and all persons acting on its or their behalf (collectively, "Vishay Precision Group"), disclaim any and all liability for any errors, inaccuracies or incompleteness contained herein or in any other disclosure relating to any product.

Vishay Precision Group disclaims any and all liability arising out of the use or application of any product described herein or of any information provided herein to the maximum extent permitted by law. The product specifications do not expand or otherwise modify Vishay Precision Group's terms and conditions of purchase, including but not limited to the warranty expressed therein, which apply to these products.

No license, express or implied, by estoppel or otherwise, to any intellectual property rights is granted by this document or by any conduct of Vishay Precision Group.

The products shown herein are not designed for use in medical, life-saving, or life-sustaining applications unless otherwise expressly indicated. Customers using or selling Vishay Precision Group products not expressly indicated for use in such applications do so entirely at their own risk and agree to fully indemnify Vishay Precision Group for any damages arising or resulting from such use or sale. Please contact authorized Vishay Precision Group personnel to obtain written terms and conditions regarding products designed for such applications.

Product names and markings noted herein may be trademarks of their respective owners.